

## Troubleshooting

### Problem and Potential Cause

#### Low Capacity or Pressure

- Incorrect direction of rotation. Make sure the fan rotates in same direction as the arrows.
- Poor fan inlet or outlet conditions. There should be a straight clear duct at the inlet or outlet.
- Improper wheel alignment

#### Excessive Vibration and Noise

- Damaged wheel.
- Loose fasteners.
- Speed too high.
- Incorrect direction of rotation. Make sure the fan rotates in same direction as the arrows.
- Wheel set screws loose.
- Bearings need lubrication or replacement.
- Debris in impeller.
- Fan surge.
- See "Use of Variable Frequency Drives."

#### Overheated Motor

- Motor improperly wired.
- Incorrect direction of rotation. Make sure the fan rotates in same direction as the arrows.
- Cooling air diverted or blocked.
- Improper inlet clearance.
- Incorrect fan speed.
- Incorrect voltage.

#### Overheated Bearings

- Improper bearing lubrication

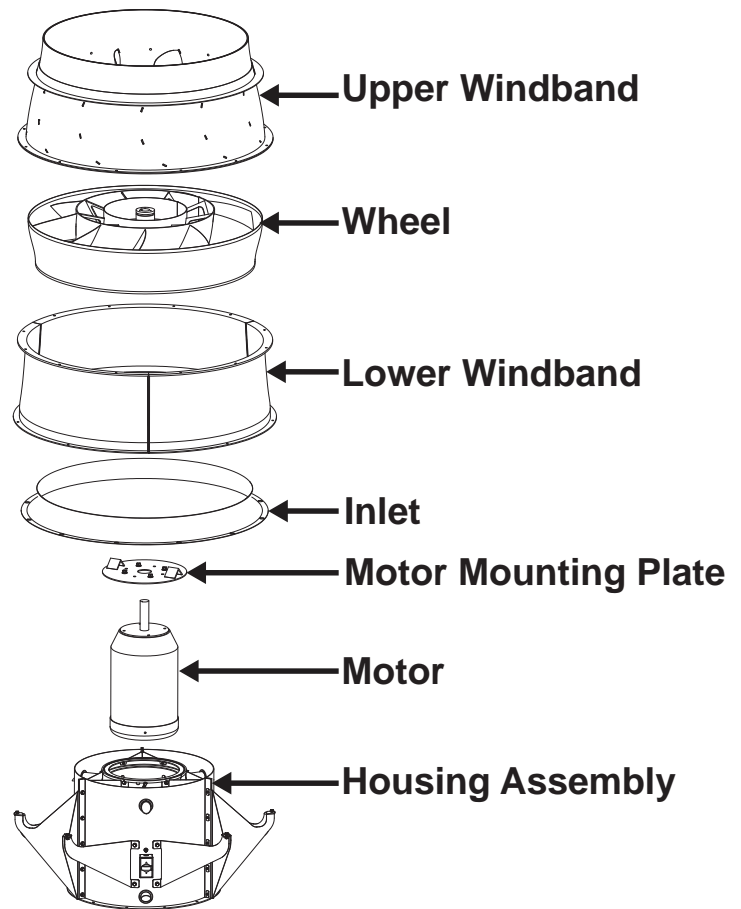

## Limited Warranty

Loren Cook Company warrants that your Loren Cook fan was manufactured free of defects in materials and workmanship, to the extent stated herein. For a period of one (1) year after date of shipment, we will replace any parts found to be defective without charge, except for shipping costs which will be paid by you. This warranty is granted only to the original purchaser placing the fan in service. This warranty is void if the fan or any part thereof has been altered or modified from its original design or has been abused, misused, damaged or is in worn condition or if the fan has been used other than for the uses described in the company manual. This warranty does not cover defects resulting from normal wear and tear. To make a warranty claim, notify Loren Cook Company, General Offices, 2015 East Dale Street, Springfield, Missouri 65803-4637, explaining in writing, in detail, your complaint and referring to the specific model and serial numbers of your fan. Upon receipt by Loren Cook Company of your written complaint, you will be notified, within thirty (30) days of our receipt of your complaint, in writing, as to the manner in which your claim will be handled. If you are entitled to warranty relief, a warranty adjustment will be completed within sixty (60) business days of the receipt of your written complaint by Loren Cook Company. This warranty gives only the original purchaser placing the fan in service specifically the right. You may have other legal rights which vary from state to state.

# LOREN COOK COMPANY

2015 E. Dale Street Springfield, MO 65803  
417.869.6474  
lorencook.com